

# BEHAVIORAL CONTINGENCY ANALYSIS

Francis Mechner

*The Mechner Foundation*

**ABSTRACT:** This paper presents a formal symbolic language, with its own specialized vocabulary, grammar, and syntax, for codifying any behavioral contingency, including the multi-party complex contingencies encountered in law, economics, business, public affairs, sociology, and education. This language specifies the “if, then” and temporal relationships between acts and their consequences. It provides for the notation of the probabilities, magnitudes, positive or negative valences, or time delays of the consequences for the parties, and of the parties that would perceive, misperceive, predict, or mispredict events. The language’s fractal-like, hierarchical and recursive grammatic structure provides for the flexible combination and permutation of the modifiers of the four nouns—acts, consequences, time intervals, and agents of acts—and four verbs, with the resulting achievement of the myriad nuances of meaning required for the analysis and codification of such complex contingencies as fraud, betting, blackmail, various types of games, theft, contracts, racing, competition, mutual deterrence, feuding, bargaining, deception, borrowing, insurance, elections, global warming, personal tipping, vigilance, sexual overtures, decision making, and mistaken identity. Issues in the application of the language to the management of practical situations, and techniques for doing so, are discussed. *Key words:* behavioral contingencies, contingency analysis, acts and consequences, notation system, behavior diagramming or codification, simulation, operations research, contingency language, grammar and syntax, linguistic analysis, formal languages.

## Behavioral contingencies

### *What are they?*

Behavioral contingencies<sup>1</sup> are the “if, then” rules and conditions that influence what people do and don’t do. The “if” part specifies some behavior; the “then” part some consequence for the involved party(ies). A price label on a product in a store communicates a behavioral contingency: if you pay that price (the behavior), you get the product (the consequence). The various effects of that contingency might include purchasing patterns, sales for that product, and competitive pricing by other stores.

Behavioral contingencies exist independently of the possible behavioral dynamics they may generate, and independently of what behavior actually occurs as a result of their existence. The price label contingency is in effect even if no one ever sees the price label or buys anything. In general, a behavioral contingency is of practical interest if it has behavioral effects that are of practical interest.

---

<sup>1</sup> The term was originally used in this way by B. F. Skinner.

### ***Behavioral contingencies in human affairs***

Behavioral contingencies, often rather complex ones, are at the root of the behavioral phenomena in such diverse realms as law, business, education, economics, management, public affairs, and the social sciences, as well as in mundane area like child management and everyday interactions between people.

*Prominent examples:*

- A body of laws, as well as contracts, agreements, and treaties, consists, in general, of “if, then” statements of the form, “If a person does or doesn’t perform certain acts, certain consequences for that person shall follow.” These are, in essence, behavioral contingency statements intended to regulate, influence, or modify behavior in a society.
- Education systems involve the behavioral contingencies that govern the interactions of students, teachers, parents, administrators, unions, religious leaders, textbook publishers, and members of the community.
- When business managers seek to improve operations by instituting more effective incentive compensation systems, work flow systems, and safety practices, they operate in large part on the behavioral contingencies involved.
- The rules of games, ranging from simple ones like tic-tac-toe to complex ones like baseball, bridge, poker, or chess, are behavioral contingencies that determine how the games are played.
- Many interactions between people involve contingency statements of the general type “If you do A, I will do B,” including promises, enticements, requests, and implied threats, as well as far more elaborate conditional statements that may refer to other parties, time periods, uncertainties, or contain qualifications.

The reason behavioral contingencies are of practical significance in the management of human affairs is that unlike the other major determiners of behavior, like the personal histories of the involved parties and the relatively immutable realities of physics and biology, behavioral contingencies can be modified, adjusted, and designed. The behavioral sciences can provide guidance in making such adjustments and modifications.

### ***Behavioral contingencies and “rules”***

The effects of a prevailing behavioral contingency on an individual’s behavior depend on the individual’s history or previous experience with that contingency or with related ones. *Example:* The effect of a price tag depends on the individual’s ability to read, affluence, and desire for the product. For verbal individuals, a contingency can be communicated by verbal descriptions of it, often referred to as “rules.” For nonverbal individuals, a contingency can be communicated by other kinds of signals,<sup>2</sup> with effects similar to those of rules, and, like rules, the

---

<sup>2</sup> The term “signal” is used here in the sense of the technical term “discriminative stimulus.” The traditional term “stimulus” is avoided here because of its connotation of stimulus-response and reflex phenomena.

information they convey to the individual about a contingency can be accurate or inaccurate, complete or incomplete, well understood or only partially understood.

### ***Independent and dependent contingencies***

Independent contingencies are those that are designed or imposed, while the dependent contingencies are those that the parties generate for each other through their behavioral interactions that result from the independent contingencies. For example, a law—one kind of independent contingency—can generate the dependent contingencies resulting from breaking or circumventing it, like bootlegging in the case of prohibition, which in turn generate further dependent contingencies. And the rules of a game produce the dependent contingencies that are inherent in the playing of the game, like the contingencies that one poker player's tendency to bluff or to play recklessly would create for the other players. The distinction between independent and dependent contingencies was first made by Weingarten and Mechner in 1966.

### ***The study of behavioral contingencies***

Given their central place in behavioral science and its applications, behavioral contingencies are worthy of study in their own right. The present paper presents a systematic way to codify and analyze even the most complex ones by providing a formal technical language with its own specialized vocabulary, grammar, and syntax.

Although the codifications provided by the use of formal symbolic languages (e.g., those of mathematics, symbolic logic, chemistry, or musical notation) can usually also be expressed by means of natural language, they provide the obvious advantage of cutting across all natural languages, with codifications that are succinct and avoid ambiguity. They can also reveal relationships among elements that would not be revealed as clearly by natural language descriptions.

While the antecedent of the present language was developed as a tool for the specification of independent variables and experimental procedures (Mechner, 1959; Mechner & Latranyi, 1963), and has also found pedagogic uses like those cited below, the present expanded language is designed for the concise, unambiguous, and schematic codification of any behavioral contingency, including complex multiparty contingencies like those mentioned above.

Clearly, this type of language cannot generate new knowledge about behavior, or make empirical assertions of any kind, as behavioral contingencies do not describe or predict what behavior will actually occur—they only describe some of the consequences for the parties involved *if* the specified behavior *does* occur.

### ***Related work***

While this paper may be the first effort to develop a generally applicable language for analyzing behavioral contingencies, limited notation systems for

behavioral contingencies have been proposed in the past. The original language and notation system for codifying behavioral contingencies (Mechner, 1959) dealt with examples drawn mainly from the experimental psychology literature on schedules of reinforcement, escape and avoidance behavior, discrimination learning, and maze learning. Weingarten and Mechner (1966) took an initial step in extending the language to contingencies involving multiple parties.

B. F. Skinner proposed a notation for describing certain schedules of reinforcement graphically (Skinner, 1958). Arthur G. Snapper adapted the computer language sometimes termed “state notation” (Snapper et al., 1982; Stephens, 1977; Tanaka & Nomura, 1993) for the computer control of certain types of behavioral experiments. Snapper’s state notation is a composite of flow charting notation and natural language. It incorporates such terms as “on,” “off,” “with  $p=n$ ,” “else,” and “then” within the diagrams proper.

In a detailed comparison of the Mechner 1959 notation system for behavioral contingencies and state notation, Jack Michael suggested that both the Mechner language and state notation are useful as teaching tools, and reported his use of the Mechner language in the undergraduate and graduate courses he taught at Arizona State University (Michael, 1995). Michael also used the Mechner 1959 language for his laboratory manual (Michael, 1963), and it was also used in the textbook *Behavior Analysis and Learning* (Pierce & Epling, 1995). A stripped-down version of it was used in a laboratory instruction manual (Millenson, 1979).<sup>3</sup>

## **The language’s vocabulary, grammar, and syntax**

### ***The elements of the language***

The present paper attempts to demonstrate the generality of the proposed language, and to show how its sparse vocabulary and simple grammar can describe a wide range of complex behavioral contingencies in diverse domains.

The units of any formal symbolic language reflect the conceptualizations of the field of application: The basic units of chemical notation are atoms; those of musical notation are notes; and those of the present behavioral contingency language are acts  $A$ ,<sup>4</sup> time intervals  $T$ , consequences  $C$ ,<sup>5</sup> and the involved parties (designated here by lower case letters). These are the language’s six basic elements:

---

<sup>3</sup> Some behavioral notation systems or paradigms (e.g., Chisholm & Cook, 1995; Findley, 1962; Goldwater & Acker, 1995; Keller & Schoenfeld, 1950; Malott, 1993; Mattaini, 1995) have been used for codifying behavior analysis principles for instructional purposes and for describing actual behavior and behavior repertoires—behavioral phenomena that actually occur as opposed to behavioral contingencies as such. These behavioral notation systems have no direct relevance to the theme of the present paper.

<sup>4</sup> The term “act” is used here, instead of the traditional term “response,” which tends to connote a stimulus-response reflex, and a brief response performed by a single individual.

<sup>5</sup> The term “consequence” is used in favor of the traditional term “stimulus,” again to avoid the “stimulus-response” connotation.

1.  $A \rightarrow$ , which is read as, “If act  $A$  is performed then ... (a consequence).” Thus every  $A$  is preceded by an implied “If.”
  2. Agent of the  $A$ : The agent(s) of an act  $A$  are designated by arbitrarily chosen letters placed in front of the  $A$  (e.g.,  $aA$ ,  $bcA$ ).<sup>6</sup>
  3.  $T \rightarrow$ , read as “upon termination of time  $T$  ...”
  4. A consequence  $C$  is any situation or event resulting from an  $A \rightarrow$  or a  $T \rightarrow$ . The term refers broadly to all relevant aspects of the prevailing environment.
  5. Prevention of a consequence: A consequence is prevented when an arrow leading to it is cut by a vertical arrow originating from another  $A$  or  $T$ , like this:  $\dashv\rightarrow$
  6. Simultaneity of onset: A bracket enclosing vertically listed  $A$ s,  $T$ s, or  $C$ s indicates simultaneity of onset of the listed conditions. For instance, an  $A$  and a  $C$  shown inside a bracket, like this,  $\left[ \begin{array}{l} A \rightarrow \\ C \end{array} \right.$  would be read as “When  $C$  is present then if  $A$ , then ...” The order in which the conditions are listed has no significance.
- Only  $A$ s or  $T$ s can *consequence*<sup>7</sup> other events—whether  $C$ s or further  $A \rightarrow$  or  $T \rightarrow$  contingencies. Thus, arrows can never emanate from a  $C$ , only from an  $A$  or a  $T$ . For example, if the analyst wishes to indicate the duration  $T$  of a consequence  $C_1$ , a new consequence  $C_2$  then replaces  $C_1$ , and the notation is  $\left[ \begin{array}{l} T \rightarrow C_2 \\ C_1 \end{array} \right.$ .

#### **Architecture of the grammar: The four quadrants**

The diagram on the next page shows the hierarchical and recursive infinite regress characteristic of the language’s quadrant-based syntax, with the four nouns  $A$ , party designators,  $C$  and  $T$ , at the center. Each quadrant is allocated to one of the four categories of modifiers in a consistent way. All quadrants but the lower right one, in turn, have the corresponding four quadrants, and these again have their own four, in a theoretically infinite regress, fractal mode.

The subscript (lower right quadrant, e.g., the numeral 1 in  $aA_1$ ) is normally an arbitrary numeral indexed to a legend where the referenced entity is described.

The superscript (upper right quadrant) is allocated to the entity’s attributes—which can be viewed as adjectives and adverbs. In the case of a  $C$ , this quadrant shows the  $C$ ’s probability, magnitude, or valence, representing a positive, negative, or unknown consequence for a certain party or parties. For entities other than  $C$  as well, that quadrant can show attributes like probability  $p$  or magnitude  $M$ , and for time intervals  $T$  it can also show variability  $v$ .

The pre-subscript (lower left quadrant) of an entity indicates the party(ies) that would *perceive* the entity, and the pre-superscript (upper left quadrant) indicates the party(ies) that would *predict* the entity.

The contingency  $aA_1 \rightarrow bA_2 \rightarrow$  is read as “If  $aA_1 \rightarrow$  then if  $bA_2 \rightarrow$  then...” If

<sup>6</sup> The term “agent” or “party” refers to individual, group, team, company, agency, populace, country that would perform an act or would be somehow affected.

<sup>7</sup> The verb *consequence* has been used in behavior analysis and is useful in the present context. The alternative verbs “produce,” “generate,” or “cause” tend to carry undesired epistemological baggage.

the desired meaning is “If  $aA_1 \rightarrow$  then  $bA_2$ ,” then  $bA_2$  would have the status of a consequence and would be shown as  $C_1$  with the legend stating that  $C_1$  is  $bA_2$ .

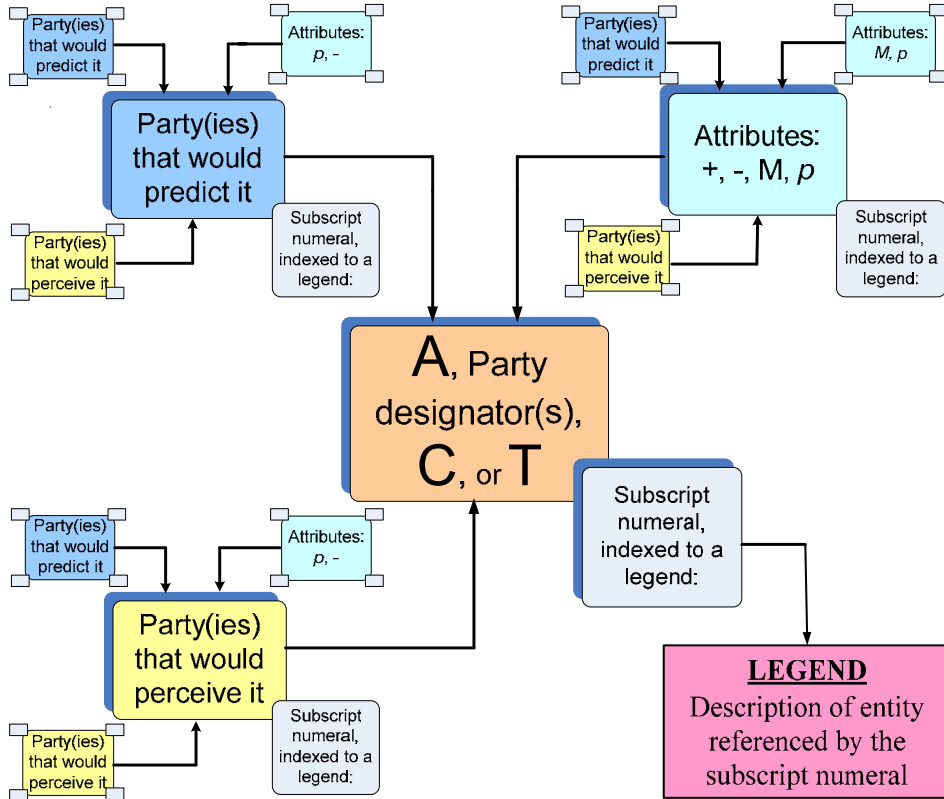

That, in essence, is the language’s grammatical structure. The remainder of this paper shows how this language can be applied to the codification of a wide range of behavioral contingencies and their nuances. One of the theses of this paper is that the verbs *perceive* and *predict* are a unique and parsimonious key to the generality of the language’s applicability.

***The subscript: Indexing to a legend***

Arbitrary subscripts (usually numerals) can index the diagram’s symbols to descriptions in a legend. When such descriptions consist of one or two words, it may be convenient to show them in the diagram proper, but wordy or complex descriptions can be elaborated in a legend to which they are indexed.

For example, the expression  $a_7A_5$  would mean that the nature of act  $A$  is described in the legend under the arbitrary numeral #5, and that party  $a$  is described in the legend under arbitrary numeral #7 as a particular individual, a group like a team, a population, a government, or an external agency, with possible further descriptions of these.

Without subscripts and legend, every diagram would represent an infinite number of contingencies that have the same structure. Specificity can be achieved only by the use of subscripts indexed to a legend. Conversely, every situation that is analyzed can be described by an endless variety of different contingency structures, depending on the analyst's desired emphasis, focus, and objective.

### *Attributes of entities*

*Valence of a C:* When a  $C$  has a positive or negative valence (a possible attribute of  $C$ ) for, say, party  $a$ , this is shown as  $C^{a+}$  or  $C^{a-}$ . If the analyst does not consider the valence relevant to his focus, the valence sign is omitted. The party(ies) affected by the valence(s), are shown before every plus or minus sign in the upper right quadrant, e.g.,  $C^{a+, b-}$ , or  $C^{ab-}$  when the valence applies to both..

*The magnitude attribute M:* For an act  $A$ ,  $M$  could refer to such intensive dimensions as level of effort, force, effectiveness, duration, frequency, number of votes, or an amount of money being paid or wagered. For valence signs, it would show the magnitude of a positive or negative consequence for a particular party. For a  $C$ , the  $M$  might refer to any scalable dimension, such a value or amount of money. For time,  $T^M$  refers to duration.

*Probability:* A lower case  $p$ , or an actual value of a probability shown in an entity's upper right quadrant, indicates the analyst's belief regarding the probability that the entity would occur.

*Variability:*  $T^V$  indicates that a time period  $T$  is variable or indeterminate.  $M^V$  indicates that the magnitude is variable or indeterminate.

These attributes are sufficient for the codification of the diverse examples used in this paper.

### *The notation of perception*

In  $A \rightarrow_{ab} C$ , the lower left quadrant of  $C$  indicates that both parties  $a$  and  $b$  would<sup>8</sup> perceive the consequence  $C$  of act  $A$ . To show that party  $a$  would *not* perceive  $C$  but that  $b$  would, the notation is  $A \rightarrow_{\bar{a}b} C$ , with the  $a$  designator having a tilde sign above it (an importation from symbolic logic, meaning "not  $a$ ").<sup>9</sup>

---

<sup>8</sup> The term "would" or "will" is used throughout, to maintain consistency with the conditional "if, then" logic of the contingency statements, e.g., "If act  $A$ , then party(ies)  $a$ ,  $b$ ,  $c$  would or will perceive or predict a designated entity." A statement of the form that  $a$ ,  $b$ , or  $c$  actually *do* perceive or predict an entity, without the qualification of conditionality, would be inconsistent with the definition of behavioral contingency statement.

<sup>9</sup> Since the tilde sign, as used here to mean "not," is an adjective and an attribute of the entity it modifies, it should, properly, be in the entity's upper right quadrant, but it is placed above the entity for the sake of convenience. In symbolic logic, it is usually placed in front of the character, but here this placement would have the drawback of the multiplicity of the meanings (including "approximately") that such a placement has in various other contexts.

$aA \rightarrow \tilde{a}bT \rightarrow abC$  is read as “If party  $a$  does act  $A$ , then after time lag  $T$ , consequence  $C$ . The  $C$  would be perceived by both  $a$  and  $b$ , and the time lag would be perceived by  $b$  but not by  $a$ .” The analyst would show  $T$  without any pre-subscript if he considers perception of the time lag not relevant to his focus.

${}_b aA \rightarrow$  would mean that  $b$  would perceive  $A$ 's agent as being  $a$ .

### *The notation of misperception*

${}_a C$  implies that party  $a$ 's perception of  $C$  would be “correct” in the sense that it corresponds to the analyst's belief. If the analyst wishes to show that the perception would be a “misperception”<sup>10</sup> or an idiosyncratic perception, the misperceiving party's designator, still shown in the lower left quadrant, would have the letter  $x$  in its own upper right (attribute) quadrant. For example, when the misperceiving party would be  $a$ , and  $b$  is the party that would perceive the  $C$  in the

same way as the analyst, the diagram would be  $a^x b C$ . If the analyst wishes to elaborate on the misperception, he could explain, under the legend's numeral 5,

$a^x_5 b C$  that  $a$  would, for example, misperceive a neutral comment as hostile. The term “misperception” is used broadly here to subsume any perception that is idiosyncratic or “subjective,” in the sense that it deviates from what an objective observer would perceive, or from the analyst's belief.

### *Perception of valences*

The pre-subscript notation to indicate that a party would perceive (or misperceive) a consequence  $C$  raises the question of whether that party would then also perceive (or misperceive) the  $C$ 's valence. The distributivity rule, which states that any perception, non-perception, or misperception of the  $C$  also applies to its valence, means that it would.

$aA \rightarrow abC^{b-,a+}$  could mean that  $a$  would harm  $b$  and benefit himself, with both  $a$  and  $b$  perceiving this consequence and its valences. If either  $a$  or  $b$  would not perceive all or part of these valences, that party's designator would be shown, with a tilde over it, in the lower left quadrant of the non-perceived valence term, to supersede the transitivity rule.

For example, to show that  $a$  would *not* perceive the  $C$ 's valence  $b^-$  in spite of perceiving the  $C$  itself, the  $b^-$  valence symbol would need the additional pre-subscript  $\tilde{a}$  to supersede the distributivity rule. If the  $\tilde{a}$  were shown as  $\tilde{a}bC^{b-}$ , the meaning would be that  $a$  would perceive neither  $C$  nor its valence, in which case the  $b^-$  valence symbol would not require the  $\tilde{a}$  pre-subscript.

$abC^{\tilde{a}b-,a+}$

<sup>10</sup> In behavior analysis terminology, misperception means responding to a stimulus as if it were another stimulus.

### *Misperception of valences*

It is possible to perceive a  $C$  correctly and to misperceive its valence. Adam and Eve might have perceived the apple correctly, but misperceived its valence for them; one might perceive a painting one is buying but misperceive its value, the value being the valence. Of course, it is also possible to misperceive both the  $C$  and its valence, as when one misperceives a poisonous mushroom as belonging to a non-poisonous species, and, when eating it, misperceiving its valence.

The valence shown in a diagram is the one the analyst considers the real one. A misperceived valence is not necessarily perceived as the opposite; it can also be perceived as neutral or as pertaining to another party. The precise nature of the misperception the analyst has in mind could be described or discussed in a legend.

To show that a valence would be misperceived by a party, that party's designator, with the letter  $x$  in its upper right quadrant, is shown in the misperceived entity's lower left quadrant. These are the various combinations:

- $aC^{a-}$   $a$  perceives both  $C$  and its negative valence for itself.
- $aC^{axa-}$   $a$  perceives  $C$  and misperceives its negative valence for itself.
- $axC^{a-}$   $a$  misperceives both  $C$  and its negative valence for itself.
- $aC^{\tilde{a}a-}$   $a$  perceives  $C$  and does not perceive its negative valence for itself.
- $\tilde{a}C^{a-}$   $a$  does not perceive either  $C$  or its negative valence for itself.

### *Misperception of a party designator: Who done it?*

The diagram on the left shows that  $b$  perceives that  $a$  is the agent, and the diagram on the right shows that  $b$  misperceives the fact that  $a$  is the agent.

$$b a A \quad b^x a A$$

This issue could come up in false accusations or in criminal law where there can be divergent beliefs regarding the agent of an act. Again, the precise nature of the misperception would be described in a legend.

Analogously, the notation  $a^x T$  means that  $a$  would misperceive  $T$ , and the notation  $\tilde{a} T$  means that  $a$  would not perceive  $T$  at all. *Note:* The distinction between misperception and non-perception is usually important.

### *Prediction*

A party's prediction of a consequence can be the result of prior exposure to

the contingency, of experience with it, of a verbal or non-verbal communication of it, or of a signal previously associated with the contingency. Signals consisting of verbal statements of contingencies are sometimes called rules.

Prediction of a consequence by a party is a function of aspects of the party's history and of the characteristics of the signal, like its perceptibility or communicative effectiveness. Thus, the analyst's indication that a party would predict a consequence reflects the analyst's belief regarding the party's relevant history.

A signal that might cue a party's prediction of a consequence has the status of a  $C$ , which may be consequated by an external agency  $e$  as well as by one of the parties involved in the contingency proper. *Examples of externally consequated Cs*: The hand that a bridge player would be dealt, a test item presented to a test taker, or a situation caused by the physical environment. In these cases, the external agency would be the card dealer, the formulator of the test item, the promulgator of the rule, or the physical environment. Acts by such external agencies  $eA$  would be shown only if the analyst considers that aspect of the contingency significant and relevant to his intended focus.

### ***The notation of "predict"***

The party(ies) that would predict the  $C$  are designated in the  $C$ 's upper left quadrant, like this:  ${}^aC$ . The diagram  $\mathbf{aA} \rightarrow {}^a\mathbf{C}$  shows that party  $a$  would perceive  $C$  when it occurs and would also predict it.

In the diagram  $\mathbf{aA} \rightarrow {}^a\mathbf{C}$ , the  $a$  in the upper left quadrant of  $C$  means that  $a$  would predict  $C$  when performing act  $A$ , but would not *perceive*  $C$  (note the  $\tilde{a}$  in  $C$ 's lower left quadrant). *Examples*:

- Committing suicide
- *Predicting* the consequence of sending a letter without *perceiving* that consequence when the letter reaches its destination
- An executive issuing an order may *predict* the order's consequence but might not *perceive* that consequence.

The reverse is  $\mathbf{aA} \rightarrow \tilde{a}\mathbf{C}$ : A party would perceive a consequence when it occurs but would not have predicted it. In such a case we might say that  $a$  would be surprised by  $C$ .

Omission of a party's designator from any quadrant means that the analyst considers it irrelevant or unimportant whether the party(ies) whose designator is omitted would predict or perceive the entity.

When the verb *predicts* is applied to a probability, the meaning is similar to that of the verb "estimates." The expression  ${}^ap_1$ , for instance, would be read as party  $a$ 's prediction/estimation of  $p_1$ . In the diagram  $\mathbf{a}^{p_1}\mathbf{p}_2$ ,  $p_1$  is the probability that  $a$  predicts/estimates the probability  $p_2$  as being  $p_2$ .

In summary,  ${}^ap_2$ , means that  $p_2$  represents party  $a$ 's prediction/estimation of

$p_2$ . The  $p_1$  in the upper right (attribute) quadrant of the predicting party designator  $a$  means that  $p_1$  is the probability of  $a$  making that prediction/estimation.

***Wrong predictions: Getting swindled, wrong number, “friendly fire”***

A party might predict a certain consequence when doing  $A$ , but a different consequence might actually occur. *Examples:* Dialing an incorrect phone number in error; paying a swindler for non-existent real estate where the actual consequence would be receiving an invalid deed; a soldier shooting one of his own men; and a suicide bomber who may correctly predict the physical and political consequences of his act but mispredict the heavenly reward that awaits him. These examples would all be represented simply as  $aA \rightarrow a^x C^{a-}$ . The  $a^x$  in the  $C$ 's upper left quadrant shows that  $a$  would mispredict  $C^{a-}$ .

These examples also make the point that only consequences that would actually occur (in the analyst's view) can be codified. Consequences that would *not* occur cannot. We may speak of a party's “intent” or “expectation,” but the contingency language cannot codify these. It can state only that the party would have predicted a consequence that differs from the actual one.<sup>11</sup>

In the above examples,  $a$  would mispredict the consequence in each case. The diagram would show only the *actual* consequences in the three cases—calling the wrong party, obtaining an invalid deed, shooting a friend, and blowing oneself up. Only the legend would state what the parties may have intended or expected—calling the desired party, obtaining a valid deed, shooting an enemy, and enjoying certain promised heavenly rewards.

To show that  $a$  would also *perceive* the actual consequence if and when it occurs in each of the above examples, the  $a$  would also be shown in the lower left quadrant of the  $C$ , as in  $aA \rightarrow a_a^x C^{a-}$ .

***Perceiving or predicting another party's perception or ability to predict***

$aA \rightarrow b C^{a-}$  means that party  $b$  would predict that  $a$  would hurt himself. The notation  $a^x C^{a-}$  means that  $a$  would mispredict it. To show that  $b$  would also *perceive* that  $a$  was mispredicting  $C^{a-}$ , the  $b$  would be shown in the lower left quadrant of the  $a^x$ , like this  ${}_b a^x C^{a-}$ . To show that  $b$  would, in addition, predict correctly that  $a$ 's act would be hurtful to  $a$ , the diagram would be  ${}_b a^x, b C^{a-}$ .

---

<sup>11</sup> In cases where the act's agent would also predict the act's consequence, one would ordinarily say that the consequence is intentional. However, the terms intention, intentional, or intend, as well as expectations, hopes, visualizations, goals, etc. are not part of the contingency language and are not needed.

***Unpredicted effect on another party's behavior***

When a party *a* would misuse a word in an unfamiliar language or give someone faulty driving instructions for getting somewhere, the consequence that *a* would be predicting is different from the consequence that would actually occur. In both of these cases, the consequence would be an unpredicted effect on the behavior of another party. When a word is misused, the consequence might be derision or puzzlement by the other party. When faulty driving instructions are given, it might be the other party getting lost and complaining. In both cases, the actual consequence is negative for *a*.

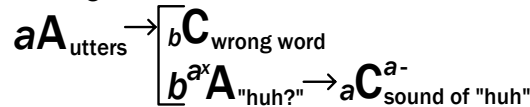

If *aA* (uttering the wrong word), and  $C_{\text{wrong word}}$  is the utterance of that word perceived (heard) by *b*, it is the sound of *b*'s puzzled reaction "huh?" to the word that would constitute the negative consequence for *a*, not the *C* representing the wrong word. If the listener *b* nods politely in spite of puzzlement, this would be a form of deception by *b*, because *a* would misperceive the nod as indicating that *b* understood, and *b* would probably predict this misperception.

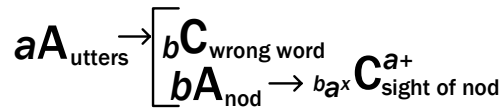

The *b* in the upper left of the  $a^x$  indicates *b*'s prediction of *a*'s misperception. The consequence of the nod for *a* is the sight of *b*'s nod. The misperception by *a* of the nod would be the actual (positive) consequence of the nod for *a*.

***Why the terms "aware," "intend," and "expect" are not used***

It may be tempting to say that an agent is "aware" of a particular contingency or consequence. However, the term is imprecise in that it does not distinguish between perception and prediction, or between a contingency and a consequence. The terms *perceive* and *predict*, on the other hand, can be modified by probability, or as a *misperception* or *misprediction*, unlike the term "aware."

Similarly, it may be tempting to say that an agent would "intend" or "expect" a certain consequence. But these terms are imprecise in that they do not tell us if an intent or expectation is still present if the prediction is modified by a probability or if the consequence is delayed by a time interval. The contingency language provides for such precision, and yet is able to express the concept of "intent" fully by stating that the act's agent *predicts* the act's consequence.

***The grammar of consequences***

A general default feature is that only one consequence *C* is present at one time, because every *C* is presumed to include all of the relevant features of the

situation. Thus any change of  $C$  is a new, again all-inclusive,  $C$  produced by a further  $A$  or  $T$ .

Suppose, for instance, that  $A_1$  consequates  $C_{\text{tone}}$ , described as the start of a tone.  $C_2$  is a light coming on. The default rule is that  $C_2$  then replaces  $C_{\text{tone}}$  (tone alone), meaning that  $C_2$  then consists of both the light and the tone, and that  $C_{\text{tone}}$  (tone alone), having been replaced by  $C_2$  is no longer present.

Suppose, on the other hand, that the analyst wishes to show that  $C_2$ , when it occurs, would consist of the light only, and that the tone would terminate when  $C_2$  comes on. The legend would then have to state that  $C_2$ , consists of the light only, without the tone.

### ***The representation of homogeneous consequences***

All real-life acts have multiple and innumerable consequences. Of course, a party performing an act would never perceive or predict all of these, only those that may have significance. *A mundane example:* If I open the refrigerator and pour myself some juice, the consequences and time lags that I would probably perceive and predict are: that I would be drinking juice in a few seconds and that I would then rinse out my glass and put it on the drain board. I would certainly not perceive or predict all of the physical, chemical, and thermal effects of opening and closing the refrigerator or the effects of drinking the juice on my stomach chemistry.

*Weightier examples:* If a company's board of directors decided to close down a factory, they would predict certain of the consequences and their time lags, but would not predict numerous other consequences, some of which they would and some of which they would not perceive when they occurred; If a government passes a new law, they will predict some consequences but not others; If the leaders of a country start a war, they will predict some consequences but not many others.

The analyst would always narrow his analysis to those consequences that are relevant to his focus. He would represent, with a single  $C$ , all of the consequences he considers to have the same time lags, probabilities, valences for the parties, and all the same modifiers, including the party(ies) that would perceive or predict them.

### ***Diverse consequences***

On the other hand, when the modifiers of the consequences are heterogeneous and yet relevant to the analyst's focus, a single  $C$  cannot represent all of these. The analyst would then need to represent those consequences with more than one  $C$ .

*Example:* Party  $a$  introduces two parties  $b$  and  $c$  to each other. The result would be two consequences  ${}_bC_2$  ( $b$ 's perception of the situation that includes party  $c$ ), and  ${}_cC_3$  ( $c$ 's perception of the situation that includes party  $b$ ). Also,  $C_2$  and  $C_3$  may have different valences for  $b$  and  $c$ , and the three parties  $a$ ,  $b$ , and  $c$  may have different predictions or perceptions of those valences.

$$aA_1 \rightarrow \begin{bmatrix} {}_bC_2 \\ {}_cC_3 \end{bmatrix}$$

*Another example:* A business executive  $a$  assigning a task to a team consisting

of two individuals  $b$  and  $c$ . When they divide the work and each takes a different part, the consequences for  $b$  and  $c$  would necessarily be different.

***The demarcation between acts and their consequences***

In the real world, the flow of events from the beginning of an act to the end of its consequence is continuous and seamless. In diagramming, exactly where in that flow the analyst chooses to draw the demarcation line depends on the desired focus.

When the consequence of party  $a$ 's act  $aA_1$  serves as the cue for party  $b$ 's act, this consequence for  $b$  can be just the sight  ${}_bC_2$  of  $a$  performing the act, as perceived by  $b$ .

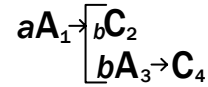

In some cases, the analyst may want to distinguish between the perception/prediction of the act itself and of the act's consequence.

It may be desired to show that a party would perceive an *act* being performed, but not its *consequence* (as in the diagram on the right). *Example*: shooting at a target (the act) and hitting it (the consequence). If  $b$  and  $\bar{b}$  were reversed,  $b$  would perceive the *consequence* but not the *consequating act*.

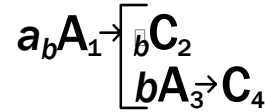

Even though it is normally assumed that an act invariably results in the expected consequence, there are cases where the analyst may assign different probabilities to the performance of the act and to its consequence occurring (*e.g.*, shooting at a target and the *probability* of hitting it). But in most applications, the analyst will apply the probability modifier only to the consequence.

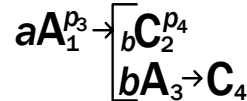

***An e-mail contingency***

The diagram below shows that  $a$  perceives that he has an e-mail,  ${}_aC_3$ , sent by an unknown external agency ( $eA_1$ ). If  $a$  opens the e-mail ( $aA_2$ ),  $a$  will see the display of the e-mail on the screen, with an attachment ( ${}_aC_4$ ).

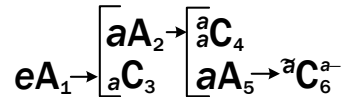

The  $a$  shown in  ${}_aC_4$ 's upper left quadrant means that  $a$  would predict that opening the e-mail would consequate the  ${}_aC_4$  image. The  $a$  in the upper left quadrant of  $C_4$  pertains only to  $C_4$  and has no bearing on the  $aA_5 \rightarrow C_6^{a-}$  contingency, namely on whether  $a$  would perceive or predict that if  $aA_5$ , the attachment would infect the computer with a virus  $C_6^{a-}$ . The  $\tilde{a}$  designator in the upper left quadrant of  $\tilde{a}C_6^{a-}$  indicates that  $a$  would not predict that opening the attachment would incur a virus. To show that  $a$  would predict it, the  $a$  would need to be shown in the upper left quadrant, like this:  ${}_aC_6^{a-}$ .

***Creating reminders, predicting an act***

Here  $aA_1 \rightarrow {}_aC_5$  can represent  $a$  writing a note to himself to take his jacket to the cleaner's. The

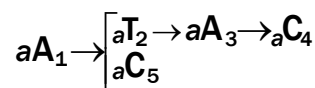

${}^a C_5$  shows that  $a$  would (obviously) perceive the note he has written. An  ${}^a C_5$  would mean that  $a$  would predict (also obviously) that  $aA_1$  (writing the note) would consequte the note, but this is probably too obvious to require being shown.

It is also possible to show that  $a$  would predict that he will *perceive* the note, by showing  $a$  in the upper left quadrant of the  $a$  in  $C_5$ 's lower left quadrant. The point being made is that it is possible to indicate the distinctions between  $a$  perceiving  $C$ ,  $a$  predicting  $C$ , and  $a$  predicting *that he will perceive*  $C$ —distinctions that may seem trivial but that can be significant in certain other situations.

To show that  $a$  would also predict his own next act  $A_3$ , *i.e.*, that upon perceiving the note he will take the jacket to the cleaner, the notation would be  ${}^a(aA)_3$ . To show that  $a$  would predict that this act will result in the jacket actually getting to the cleaner, the  $a$  would be shown in the upper left quadrant of  ${}^a C_4$ . The analyst would probably consider many of these aspects of the contingency so obvious that they don't need to be indicated explicitly. They are discussed here only to illustrate the detailed nuances of meaning that can be encoded.

### ***Codifying nuances of meaning***

The diagram on the right could mean that if  $a$  issues a request  ${}_b C_4$  to  $b$  to do  $A_2$ , then if  $b$  complies and does  $A_2$ , the consequence would be  $C_3$ . Designators in the upper left quadrants of  ${}_b A_2$  and  $C_3$  would be required (though not shown in the diagram) to indicate whether  $a$  would predict  ${}_b A_2$  and  $C_3$  respectively if and when performing  $aA_1$ .

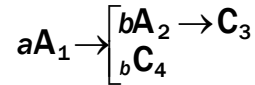

Below is a list of some of the nuances of meaning the analyst can express in the above diagram regarding his view regarding the occurrence of  ${}_b A_2$ :

${}^a({}_b A_2)$   $a$  would predict  ${}_b A_2$

${}^{a?}{}_b A_2$  The analyst is uncertain that  $a$  would predict  ${}_b A_2$ .

$({}_b A_2)^p$  The probability of  ${}_b A_2$  actually occurring is less than one.

${}_b^p A_2$   $p$  is the probability that  $b$  would be the agent of  $A_2$ .

$?^a$  in the upper left of  ${}_b$  would mean that it is  $a$ , as opposed to the analyst, who is uncertain that  $b$  would do  $A_2$ ;

$\tilde{a}$  in lieu of  $a$  in the notations described above would provide another dimension of nuances.

Replacing the  $a$  in  ${}^a({}_b A_2)$  with  $a^p$  would mean that the analyst considers the probability to be  $p$  that  $a$  would predict  ${}_b A_2$ .

In the above diagram, if the  $?$  or  $p$  are shown for  $C_3$  rather than  ${}_b A_2$ , the meaning would be that the modifiers apply to  ${}_b A_2$ 's *consequation of C given that  ${}_b A_2$  occurs*, not to  ${}_b A_2$ 's occurrence.

### ***Setting a trap***

In the diagram on the right, the valence of  $C_3$  is negative for  $b$ , and  $b$  would

not predict it, nor perceive  $C_4$ . (Note the negation symbols  $\bar{b}$  in those positions). This would describe the setting of a trap by  $a$  for  $b$ . The pre-subscripts of  $C_4$  would indicate whether  $a$ ,  $b$ , both, or neither would perceive  $C_4$ . If the negation signs were removed from the  $b$  s, the diagram would mean that  $C_4$  serves as a cue or warning to  $b$  regarding  $bA_2$  and its consequence. If  $b$  referred to a populace, the diagram would represent what is often called an advisory.

Party  $a$  would not necessarily predict that  $bA_2$  would consequate  $C_3^{b-}$ . To show that  $a$  would predict it, (and that  $a$  would therefore have set the trap “intentionally,” as one might say), the  $a$  would also be required in the upper left quadrant of the consequence, as in the diagram on the right. Additional nuances or emphases could be indicated by  $a$  s in the upper left quadrants of the  $\bar{b}$  s to show that  $a$  would predict  $b$ ’s non-perception and non-prediction of  $C_3^{b-}$ .



**Probability of a consequence: Creating a hazard**

The diagram on the right could describe a hazard for  $b$  if the analyst assigned a probability  $p$  to  $C_3^{b-}$  (the  $p$  is in the attribute quadrant of  $C_3^{b-}$ ).

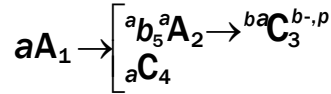

The presence or absence of a  $b$  as the additional pre-subscript of  ${}_a C_4$  would indicate whether  $b$ , in addition to  $a$ , would perceive the  ${}_a C_4$  cue or warning signal regarding the hazard of doing  $A_2$ . The  $b$ ’s subscript numeral 5 would index the legend statement as to the identity of the party or parties that could perform act  $A_2$ . The  $a$  in the upper left quadrant of  $b_5$  means that  $a$  would predict that  $b$  would be the agent of  $A_2$ . The  $a$  in the upper left quadrant of  $A_2$  means that  $a$  would predict that  $A_2$  will occur, regardless of who does it, and an  ${}^a p$  (not shown in the diagram) in  $A_2$ ’s upper right quadrant would mean that  $a$  would predict that the probability of  $A_2$  occurring would be  $p$ .

The  $b$  in the upper left quadrant of  $C_3$  (in addition to the  $a$ ) means that both  $a$  and  $b$  would predict that  $A_2$ , if it occurs, will consequate  $C_3$  and its attributes. Since  $p$  is already shown as an attribute of  $C_3$ , the question arises as to whether  $a$ ’s and  $b$ ’s prediction is therefore also tempered by the  $p$ . The distributivity rule (that entities include their attributes) would say that it is. To show that  $a$ ’s or  $b$ ’s prediction is *not* also tempered by  $C_3$ ’s attribute  $p$ , the party whose prediction is not thus tempered would have to be shown with  ${}^a p$  in  $C_3$ ’s attribute quadrant. This would be a second  $p$  in the  $C_3$ ’s attribute quadrant, shown alongside the analyst’s unmodified (“actual”)  $p$ .

**Vertical arrows that terminate and change contingencies: Theft**

A vertical arrow (initiated by an  $A$  or a  $T$ ) cutting a horizontal arrow terminates the contingency represented by that horizontal arrow and creates a new

consequence, as in the diagram on the right. (The cookie in  $a$ 's lunch box ( $C_1$ ) would be consequated by the act of an external agent (the  $eA$  is not shown because it isn't relevant to the focus)).

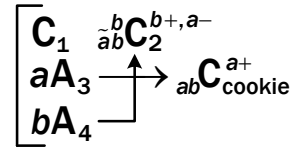

If  $b$  takes the cookie out of  $a$ 's lunch box ( $bA_4$ ) before  $a$  has done so,  $a$  would be prevented (vertical cutting arrow) from taking the cookie ( $aA_3$ ). If both  $a$  and  $b$  would predict that the cookie will end up in  $b$ 's possession ( $C_2$ ), both  $a$  and  $b$  would be shown in the upper left quadrant of  $C_2$ , rather than just  $b$  as in the diagram. If both  $a$  and  $b$  were shown as pre-subscripts in  $abC_2^{b+,a-}$ , both would perceive that the cookie is now in  $b$ 's possession. Since only  $b$  is shown as the pre-subscript, and  $a$  is shown with a negation sign,  $\tilde{a}$ ,  $bA_4$  represents a theft.

### ***Distributivity relations among the quadrants***

An entity's subscript (the numeral that indexes a legend item) may be considered distributive across all of the entity's modifiers if convenient, but this is not a rule, and the analyst may want separate subscripts for individual modifiers.

The only other distributive relations in the grammar are that the verbs *perceive* and *predict* also extend to the modified entity's attributes (shown in the upper right quadrant)—any entity that is perceived or predicted includes all of that entity's attributes. For example, suppose that party  $a$  in  $aC$  is modified by a probability  $p$  in  $a$ 's upper right quadrant and by party  $b$  in its lower left quadrant,  $bA^p$ , and the entire expression is in the lower left quadrant of  $C$ . This would mean that  $b$  perceives that  $p$  is the probability that  $a$  would perceive  $C$ .

All other relations are non-distributive. For example, if it is shown that a party would perceive a consequence  $C$ , this would not mean that this party would therefore also perceive which parties would *predict*  $C$ , that is, it would not be distributive to the upper left quadrant designators. The reverse is also true—the fact that a party would predict  $C$  would not imply that this party would therefore also predict which parties would *perceive*  $C$ . For example, to show that party  $a$ , which perceives a  $C$ , would then also perceive that another party  $b$  would predict that  $C$ , party  $a$ 's designator would have to be shown in the  $b$ 's lower left quadrant.

### ***Behavioral history factors***

Some aspects of a behavioral contingency description are independent of the history of the affected individuals, and some are not. The specification of the acts  $A$ , the time periods  $T$ , the consequences  $C$ , the parties that are involved, and certain of the attributes of the entities such as probabilities and magnitudes, reflect the analyst's beliefs about the situation, independently of how the parties may or may not react. On the other hand, such modifiers as *perceive*, *predict*, and the valences of consequences do depend on the parties' histories, and reflect the analyst's beliefs about those histories.

The significance of this is that the representation of any given situation would

depend not only on the analyst's focus, but also on his beliefs regarding the parties' histories and motivations. The representations would, accordingly, be different for different parties, and for the same party(ies) at different times.

## Diagramming techniques and examples

### *Simplifying assumptions and abbreviations*

Formal symbolic statements are inherently stripped down to presumed essentials through the use of simplifying assumptions that omit elements considered to be relatively less important. The purpose of such simplification is to eliminate complexities that might mask the intended focus.

Similarly, when diagrams of behavioral contingencies highlight the analyst's desired focus, they necessarily simplify the contingencies they purport to represent by selecting some features and omitting others. They bear the same type of relationship to real-life contingencies that a drawing of an object bears to the real object. The features that are omitted depend on the diagram's analytic objective.

A common simplifying assumption is the omission of the  $T$ s for the time lags that always intervene between every act  $A$  and its consequence  $C$ . When the analyst considers the time lag to be relevant, the contingency would be shown as  $A \rightarrow T \rightarrow C$ . When the  $T$  is not part of the analyst's focus or is not relevant to the dynamics being analyzed, the  $T$  would be omitted from the diagram. When the time periods are relevant, they would, of course be shown.

Abbreviations provide another way to simplify diagrams. For example, the symbol  $C^{a+}$  is an abbreviation. There could be several possible reasons for the valence being positive for  $a$ , and those reasons could be elaborated in the diagram proper. *Examples:* upon the occurrence of  $C$ ,  $a$  might be able to avert an impending negative consequence, or certain further acts by  $a$  might procure a positive consequence. If these reasons are not elaborated it is because the analyst considers them immaterial, or prefers not to show them in the diagram lest doing so would divert attention from the diagram's main focus. In such a case, the analyst could elaborate the reason in a separate module indexed to the point of insertion.

### *Consequence of omitting an act: Failure to pay a bill or to protect civil liberties*

There are many situations in which failure to perform an act has consequences as significant as those of performance of an act. In all such cases, the consequence  $C$  would be consequated by a  $T \rightarrow$  or by an act by another (sometimes external) party. For example, if a phone bill is not paid by the end of time  $T$ , the phone company will shut off service. In the domain of public affairs, the consequence of failure to protest an encroachment on civil liberties may be further encroachments.

In the contingency depicted above,  $b$  would be the agent of the preventive act. The terminating vertical arrow shows that  $bA_3$  would avert  $C_2$  by terminating the

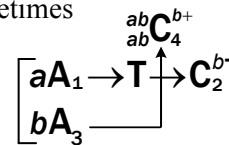

$T \rightarrow C_2$  contingency. Non-performance of  $bA_3$  would permit  $C_2$  to occur.

The legend, indexed to the subscripts:

1. If phone company  $a$  threatens to cut off service after  $T$
2. Service would be cut off.
3. (If) customer  $b$  pays the phone bill within time  $T$
4. Service would continue.

The analyst can show the consequence of the termination, including the parties that would perceive and/or predict that consequence, and the attributes (*e.g.*, valences) of the termination, by showing the  $C$  at the end of the terminating arrow. Note that at the intersection of the arrows, only the contingency represented by the horizontal arrow is terminated or changed. The horizontal arrow does not change the contingency represented by the vertical arrow.

### *Notation of fuzziness*

Uncertainty is indicated by a question mark after the entity to which the uncertainty applies. When it is the analyst who is uncertain, the question mark is shown unmodified. When it is a party who is uncertain, the uncertain party's designator is shown in the question mark's attribute quadrant.

Uncertainty regarding the *correctness* of a perception or prediction is shown as a question mark in the perceiving or predicting party's attribute quadrant.

The specific nature of the uncertainty, or the reason for it, can be elaborated in the legend. The arbitrary numeral indexing the legend could be shown in the question mark's lower right quadrant, as usual, like this:  $b?_5$ .

- $(a?)_b C$  The analyst is uncertain as to whether  $a$  would perceive the  $C$ .
- $a? C$  The analyst is uncertain as to whether  $a$  is the party predicting  $C$ .
- $a?a C$   $a$  is uncertain about the correctness of his own prediction. The question mark is in the main  $a$ 's attribute quadrant, with an additional  $a$  in the question mark's attribute quadrant.
- $a? C$  The analyst is uncertain as to whether  $a$ 's prediction is correct.
- $C^{a+/-?}$  The analyst is uncertain regarding the valence of  $C$  for  $a$ .
- $C^{a+, b+/-?}$  The analyst is uncertain as to the valence of  $C$  for  $b$  but not for  $a$ .

### *Uncertainty and probability*

An indication of uncertainty regarding an entity, on the part of the analyst or a party, means that the analyst or party lacks some existing or available information. The implication is that in principle, if that information were provided, the uncertainty would be eliminated.

When the analyst indicates a probability, on the other hand, he indicates his belief that the probability of the prevailing situation—usually an external reality like the physical characteristics of dice, decks of cards, fire arms, or earthquakes,

or the results of decision processes of others, is less than one. If doing so is relevant to his focus, he may also want to show a second branch of the consequating arrow to show the contingency for the  $1-p$  complement of the indicated probability. A probability can be modified with a party's prediction/estimation (the  $p$ 's pre-superscript), but an uncertainty cannot.

These criteria for when to use the question mark and when to use the probability notation are clearly not absolute, and no more than general guidelines, as gray area cases are common. In general, notations of uncertainty or probability are used only when they are relevant to the analyst's focus. The analyst can never be 100% certain of all the entities in a diagram, and all consequences would necessarily be probabilistic to some small degree. However, these relatively small uncertainties are usually unimportant in relation to the main focus, and can be neglected in the codifications. Uncertainties and probabilities are indicated only when they are material and affect the interpretation of the contingency.

***Reciprocal vertical arrows: Decision making and competition***

When either one of two concurrent contingencies prevents the occurrence of the other, as in decision making and certain types of competition, it is desirable to use reciprocal vertical arrows (as below).

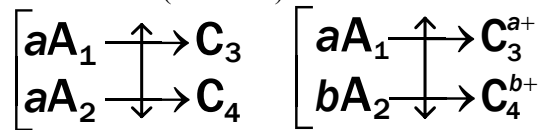

This notation is an abbreviation that simplifies the diagram so as to prevent the essential elements of the structure from being obscured. The unabbreviated way would be to show two separate vertical arrows, each one emanating from one of the two originating events and cutting the horizontal arrow of the other.

The diagram on the left represents  $a$  making a decision. The reciprocal vertical arrow is needed to show that either decision precludes the other. The diagram on the right shows  $a$  and  $b$  competing to achieve different consequences (as, for instance, in a boxing match when each tries to knock out the other, or in any zero sum game). Here, the reciprocal vertical arrow is required to show that once  $a$  has achieved  $C^{a+}$ ,  $b$  can no longer achieve  $C^{b+}$ , and vice versa. If vertical arrows were omitted, the occurrence of either  $A \rightarrow C$  would not prevent the subsequent occurrence of the other  $A \rightarrow C$ .

***Simultaneous multiple discrimination: Answering a multiple choice item***

When taking a multiple choice test, the student may be confronted with a question  $C$  to which he can respond with any one of three choices (acts), as in the diagram on the right. The external agency  $e$  that presents the question may be a teacher, a computer, or the student himself turning a

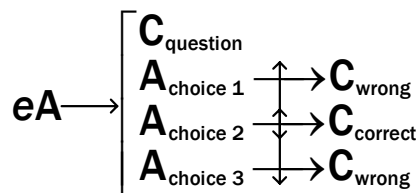

page. If  $eA$  presents the question  $C$ , the student can check one of the three boxes. The reciprocal vertical arrows show that each of the three choices terminates the availability of the others.

## “And” and “or” relationships

### “And” relationships: Cooperation, contracts, agreements

When a consequence depends on the occurrence of all of two or more events, the symbolic logic symbol  $\cap$  for the intersection of sets (the “and” relationship) is used. *Example:* Mother says to child, “I will ready you a story ( $C^+$ ) in five minutes ( $T_3$ ), if you have brushed your teeth ( $A_1$ ) and gotten into bed ( $A_2$ ) in those five minutes. Since all three conditions must be met, the logical intersection symbol  $\cap$  for the “and” relationship is required:  $(A_1 \cap A_2 \cap T_3) \rightarrow C^+$ .

The  $\cap$  symbol is also needed for diagramming cooperation among parties, as when  $a$  and  $b$  perform different and separate acts  $aA_1$  and  $bA_2$  when they cooperate. *Example:* if  $a$  and  $b$  make an agreement ( $aA_1 \cap bA_2$ ) by exchanging promises, undertakings, goods, signatures, or money, and each party agrees to perform further acts ( $aA_3 \cap bA_4$ ), namely the undertakings stated in the agreement, presumably for the parties’ mutual or joint benefit  $C^{ab+}$ , this would be represented as  $(aA_1 \cap bA_2) \rightarrow (aA_3 \cap bA_4) \rightarrow C^{ab+}$ . Of course, the terms of the agreement can be elaborated, either by expanding the diagram or in a legend. On the other hand, if the cooperative acts of  $a$  and  $b$  are thought of as a single act rather than as separate acts, the notation  $abA$  would be used instead of the expression with the  $\cap$  symbol.

### The role of time $T$ in “and” relationships: The roast in the oven

The diagram below shows a situation where  $a$  put a roast in the oven and left the house without turning the oven off ( $aA_1$ ).

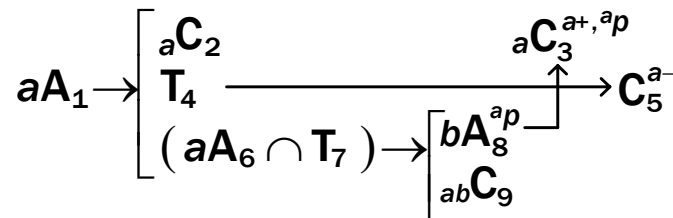

If the oven is not turned off ( $A_8$ ) within time  $T_4$ , the roast will burn ( $C_5^-$ ). If the oven is turned off ( $A_8$ ) after time  $T_7$  and before  $T_4$ , the roast will be done. But the oven will get turned off only if  $a$  asks ( $aA_6$ ) her neighbor  $b$  to do so before  $T_4$ . Thus there are two conditions connected by the “and” relationship—the time  $T_7$  and  $aA_6$ .

*Legend indexed to the subscripts:*

$aA_1$  If  $a$  leaves the roast in the oven on leaving home...

- ${}^a C_2$  The roast would be in the oven with the oven on.
- $T_4$  Time after which the roast would burn.
- $T_7$  Time after which the roast would be done.
- $C_5^{a-}$  Burnt roast
- $aA_6$  If  $a$  calls her neighbor  $b$  and leaves her a message...
- ${}_{ab}C_9$  Message to turn off the oven after time  $T_7$ .
- $bA_8 \rightarrow$  If  $b$  turns off the oven after  $T_7$  and before  $T_4$ ...
- $C_3^{a+}$  The roast is done and  $C_5^{a-}$  is averted.

The  $b$  in  ${}_{ab}C_9$ 's lower left quadrant implies that  $b$  got the message. The  ${}^a p$  attributes of  $A_8$  and  $C_3$  represent  $a$ 's prediction/estimation of the probability that  $b$  will actually do  $bA_8$  and that the roast will therefore be taken out in time.

***Types of “or” relationships: Achieving priority, putting out a fire***

One kind of “or” relationship is where one of two or more acts can result in a given consequence. Another is where a single act can result in one of two or more consequences. Both can in turn be divided into exclusive “or” relationships (either, or, but not both) and inclusive “or” relationships (either, or, or both). An exclusive “or” relationship (only one of two or more acts can produce a consequence) can be diagrammed by a merging of the horizontal arrows (see diagram on the left). The consequating entities can be  $As$  and/or  $Ts$ . That diagram could represent two parties competing to consequate  $C$ , where whoever gets there first obtains the only available  $C$  (as when parties compete for priority in applying for a patent or in reaching the South Pole).



The diagram on the right shows that either one of two parties, or both together, can put out the fire—the inclusive “or,” represented by the logic symbol  $\cup$  for union.

The  $(aA_1 \cup bA_2) \rightarrow (aA_3 \cap bA_4) \rightarrow C^{ab+}$  would be read as, “If either  $a$  or  $b$  or both (note the inclusive “or” symbol  $\cup$ ) create a situation in which cooperation between  $a$  and  $b$  (note the  $\cap$  symbol for “and”) can occur, the consequence would be favorable to both  $a$  and  $b$ .”

***Alternative outcomes with different probabilities: Russian roulette and investing in a stock***

Some “or” relationships occur when a single act  $A$  (e.g., the tossing of a coin) can result in more than one possible outcome, and these possible outcomes have different probabilities. Such contingencies can be represented in various ways, according to the analyst’s desired emphasis.

Take the case of Russian roulette. The  $1/6$  probability of the consequence

“bullet in chamber” occurring is indicated in the diagram on the left.

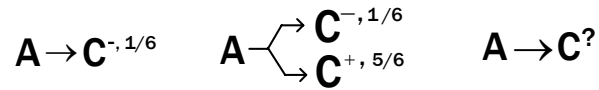

If the analyst’s focus is on the alternative scenarios, the arrow can be shown as branching, with the other branch marked with the complementary probability 5/6, pointing to a different consequence, as in the middle diagram. The diagram on the right puts the focus on the uncertainty regarding the  $C$ ’s valence. In general, contingencies involving alternative consequences are represented by a multi-pronged fork with two or more arrows pointing to the different consequences.

To show that one of the parties (as opposed to the analyst) is uncertain regarding the valence, the party’s designator would be shown in the upper right quadrant of the question mark, as an attribute of the uncertainty.

*Example:* When one invests in a stock, one is uncertain as to whether it will go up or down or neither. *Other examples:* Going on a blind date and tasting a new food. If the desired emphasis is on the probability rather than the uncertainty, the notation would be  $A \rightarrow C^p$ , an “or” situation that implies two alternative consequences,  $p$  and  $1-p$ . Each of these two  $C$ s can be conequated by one of the forks of a branching arrow.

**Modifiers that have “ifs” in front of them**

The analyst may sometimes wish to show that a modifier like *perceive* and *predict*, or a valence, has an “if” in front of it. For example, he may want  ${}_aC$  to be read as “If  $a$  would perceive  $C$ ” rather than “ $a$  would perceive  $C$ .” He would then have to show the two possibilities as the branches of an “or” fork.

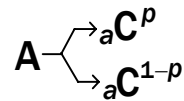

**Multiple discriminations: Traffic lights and naming people**

The psychology term *multiple discrimination* refers to contingencies in which the consequences of different acts depend on the prevailing stimuli. Which act will actually occurs usually depends on the party’s history with respect to those stimuli. For example, we stop when the traffic light is red and proceed when it is green, and call different people by their respective names.

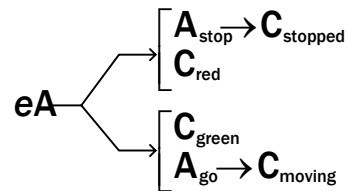

To codify this contingency, we begin by asking how the circumstances for the acts might be generated. Traffic lights are usually generated by timers, and the telephone equipment permits us to hear the voices  $C$  of the people we may want to name when they call us. All of these circumstances are conequated by an external agency  $e$ , in an “or” manner—the traffic light is either red or green, and we receive phone calls from one person at a time out of many possible persons.

The “or” relationship is represented by a fork with diagonal lines emanating from the branching point. When the multiple discrimination involves more than two choices, the arrow would have correspondingly more branches.

## Fatal Misperceptions

### Misperception of C: Mistaken identity

If policeman  $a$  sees a suspicious character  $b$  ( $aC_1$ ) he may try to arrest him ( $aA_3$ ).

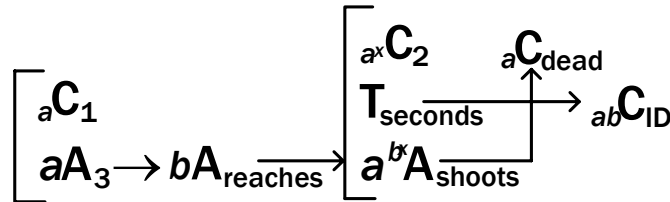

If the suspect, claiming mistaken identity, reaches into his pocket ( $bA_{reaches}$ ) to pull out his identification ( $abC_{ID}$ ), then in the  $T$  seconds this would take, the policeman could misperceive the visual consequence ( $a^x C_2$ ) of the act ( $bA_{reaches}$ ) as pulling out a gun, and shoot  $b$  dead ( $aA_{shoots}$ , mispredicted by  $b$ ).

If it were desired to show that the suspect  $b$  would not predict that the cop may misperceive  $C_2$ , a  $b^x$  would be shown in  $a^x$ 's upper left quadrant, like this:  $b^x a^x$  with the entire expressions still shown in the lower left quadrant of  $C_2$ .

### Misperception of a missile test

The same type of diagram could describe a misperception by country  $a$  in response to a detected missile test ( $bA_{test}$ ) by a hostile power  $b$  (See diagram below), and an associated series of mispredictions by  $b$ . In the diagram below,

$\tilde{a}^x C_{test}$  shows  $a$ 's misperception of the test.

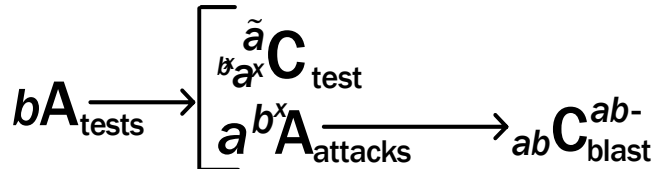

The  $\tilde{a}$  indicates that  $a$  would not predict the test (*i.e.*, it would surprise  $a$ ). If  $a$  responds with  $aA_{attacks}$  (a retaliatory attack against  $b$ ), the consequence would be negative for both parties.

The  $b^x$  in the upper left quadrant of the  $a^x$  shows that  $b$  would mispredict  $a$ 's misperception of the test. The  $b^x$  in the upper left quadrant of  $A_{attacks}$  shows that  $b$  would mispredict the attack by  $a$ . Since it is evident that  $b$  would, accordingly, also

not predict the disastrous consequence, there is no need to show  $b$ 's prediction or misprediction regarding  $C_{\text{blast}}$ .

If it were desired to show that  $b$  would *not* predict rather than mispredict how  $a$  would perceive the test, then a  $\tilde{b}$  would be shown in  $a^x$ 's upper left quadrant instead of the  $b^x$ .

***Planning a deception: The Trojan horse***

If Homer had been the analyst, he might have represented Odysseus—the general of the besieging Greeks—as party  $a$  scheming the following contingency:

“If we build a hollow wooden horse and leave it for the Trojans to find ( $aA_{\text{offers}}$ ), the Trojans (represented by  $b$ ) may (probability  $p_1$ ) misperceive the horse (as being hollow rather than filled with soldiers).

“If the Trojans thereupon take the horse through the gate into their city ( $bA_{\text{takes in}}$ ), our soldiers hidden inside the horse will be able to emerge from the horse during the night ( $aA_{\text{emerge}}$ ) and open the gates for the rest of us to enter and sack the city, thereby winning the war.”

The  $\tilde{b}$  in upper left quadrant of  $C_{\text{horse}}$  shows that the Trojans would not predict this “gift.” The  $b^x$  in the  $C_{\text{horse}}$ 's lower left quadrant shows  $b$ 's misperception, and the  ${}^a p_1$  in the  $b^x$ 's attribute quadrant shows that Odysseus was assigning a probability of  $p_1$  to the occurrence of the misperception.

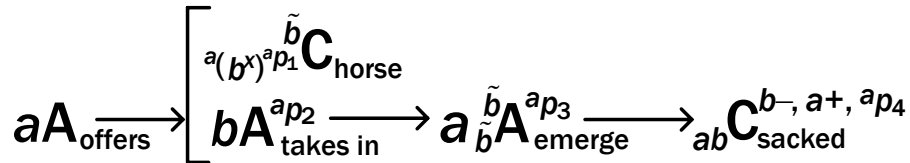

The  ${}^a p_2$  in the attribute quadrant of  $bA_{\text{takes in}}$  shows that Odysseus was assigning a probability of  $p_2$  to this possible act of  $b$ .

The  ${}^a p_3$  in the attribute quadrant of  $aA_{\text{emerge}}$  shows that Odysseus would assign a probability of  $p_3$  to the act of emerging (considering that the Trojans might discover the ruse, or that the horse's door might jam). The  $\tilde{b}$  symbols in the two verb quadrants of  $aA_{\text{emerge}}$  show that  $b$  would not perceive or predict  $aA_{\text{emerge}}$ .

The attributes quadrant of  $C_{\text{sacked}}$  shows that this consequence is negative for  $b$ , positive for  $a$ , and that  $a$  would have predicted its probability as  $p_4$ . The lower left quadrant shows that both  $a$  and  $b$  would perceive it.

If Odysseus had indeed performed this analysis and considered the product of the four probabilities, he might have concluded that his scheme was very risky.

***Alternate points of view: A sexual overture***

Here  $a$  makes a sexual overture  $aA_1$  to  $b$ . From  $a$ 's point of view, there are two possible outcomes, shown by the forked arrows as an "or" relationship, with probabilities of  $p$  that  $b$  would accept ( $bA^p_{\text{accepts}} \rightarrow abC_{\text{acceptance}}$ ) and  $(1-p)$  that  $b$  would decline. The

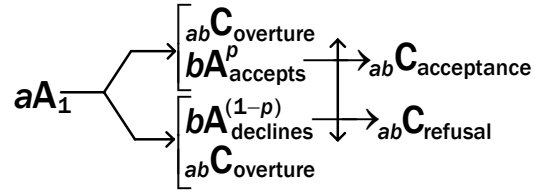

reciprocal vertical arrow is needed for  $b$ 's decision process, to show that  $b$ 's accepting and declining are mutually exclusive. If  $(bA_{\text{accepts}})$ , the consequence would be  $abC_{\text{acceptance}}$ . If  $b$  declines ( $bA_{\text{declines}}$ ) then  $abC_{\text{refusal}}$ . Note that the  $abC_{\text{overture}}$  is repeated in each of the two brackets, because from  $a$ 's point of view each alternative decision by  $b$  would be in response to the same overture.

From  $b$ 's point of view the issue is whether to accept or decline, rather than a probability issue. This type of analysis, which presents two perspectives, can be useful in fields like law, business, games, or public affairs, where analyzing each party's point of view can be important. In some business transactions, like borrowing, there are the points of view of the borrower and of the lender, and in insurance transactions there are the points of view of the insured and the insurer.

**Multiple probabilities: Vigilance, and disarming a bomb**

This example illustrates the assignment of probabilities to various consequences and actions.

If an external agency  $e$  plants a time bomb ( $eA_{\text{plant}}$ ) that has probability  $p_1$  of going off after unknown time  $T^v$ , the probability that  $a$  will be in the vigilance/detection mode ( $aA_{\text{vigilance}}$ ) will be  $p_2$ , and  $p_3$  is the probability that  $a$  will detect (perceive)  $aC_{\text{bomb}}$ . If  $a$  thereupon alerts ( $aA_{\text{alerts}}$ ) the bomb squad  $b$  (probability  $p_4$ ) with a signal ( $abC_{\text{alert}}$ ), the bomb squad will probably ( $p_5$ ) attempt to disarm the bomb ( $bA_{\text{disarm}}$ ) and the probability of successfully disarming it is  $p_6$ .

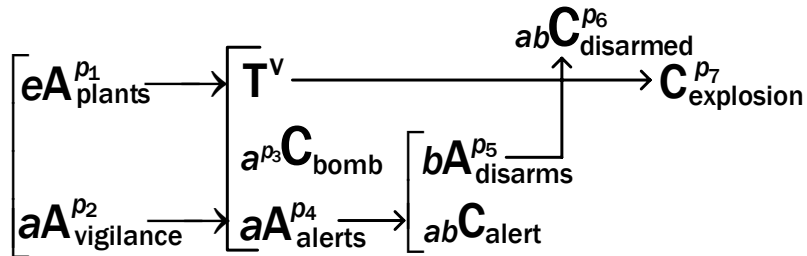

It is unknown *when* ( $vT$ ), or even *if* ( $p_7$ ) the bomb (if it is real) will go off.

**Modification of probabilities and contingencies: Mitigating a danger**

The diagram on the right shows a situation in which two or more parties act cooperatively

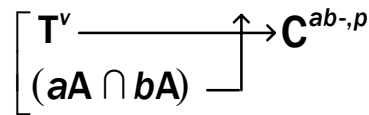

to avert a threat. As in the above example, the feared  $C^{ab}$  can come at an unpredictable time  $T^v$ , with an unknown probability  $p$ . By  $a$  and  $b$  acting cooperatively, shown as  $(aA \cap bA)$ , (which could mean, for example, exercising vigilance, building levees, or storing provisions), they can prevent  $C^{ab}$ .

To show that  $(aA \cap bA)$  merely reduces the probability of  $C^{ab}$  from  $p_1$  to  $p_2$ , rather than to zero, the consequence would be shown at the end of the vertical arrow with the new probability  $p_2$ , as in the diagram on the right. Here  $(aA \cap bA)$  would change both the timing and the probability of the terminated contingency. When the vertical arrow initiates a whole new contingency, it points to the bracket of the new contingency.

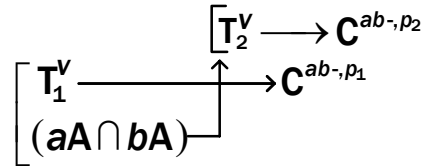

**Risky choices: Thinking ahead in a game**

A chess, checker, or go player takes three kinds of risk when choosing between moves in a game: the uncertainty regarding (1) how accurately or completely he identified the opponent's possible responses, (2) which of the identified responses the opponent will actually choose, and (3) the valence of the outcomes of these various possibilities.

The diagram on the right shows one way of representing the behavioral contingencies involved if  $a$  considers two possible moves  $aA_1$  and  $aA_9$ , and thinks two moves ahead in considering  $b$ 's possible responses. The choice between  $aA_1$  and  $aA_9$  is risky because (as could be explained in the legend)  $a$  would be uncertain as to whether, in response to  $aA_1$ ,  $b$  would choose  $bA_3$  (a particular identified move) or  $bA_5$  (a possible unidentified move), or whether in response to  $aA_9$ ,  $b$  would choose  $bA_7$  (another particular identified move) or  $bA_{10}$  (another possible unidentified move).  $A$  would also be uncertain regarding the valences of the resulting situations (note the  $a$  s in the attribute quadrants of the question marks).

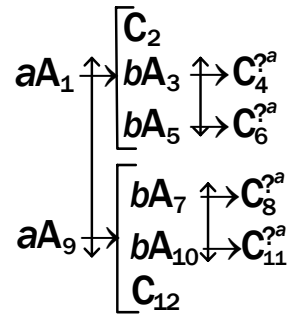

**Recycling contingencies: Blackmail and kidnapping**

To show that a contingency remains in effect, a recycling arrow is used. For example, when a CD has been played, it can be played again:

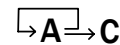

Sometimes, recycling is uncertain. If a blackmailer  $a$  threatens to harm  $b$  ( $abC_{\text{harm}}^{b-}$ ), the probability of the harm occurring might only be  $p_2$ , even if  $aA_{\text{executes}}$ . If  $aA_{\text{demand}}$  stated that  $b$  can avert harm by paying ( $bA_{\text{pays}}$ ), with consequence ( $abC_{\text{no harm}}^{b-}$ ), then it is possible that the probability that  $a$  would do

no harm if  $b$  pays is  $p_4$ , and the probability that  $a$  would actually execute the threat even if  $a$  does not pay is  $p_1$ . The probability that

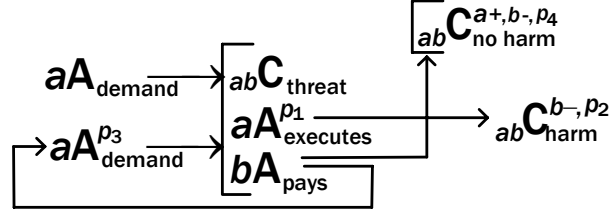

paying will result in a recycling of the entire contingency is  $p_3$ . When a complex contingency that may include vertical arrows recycles, all components of that contingency are restored for the next cycle, including ones that were terminated by vertical arrows in the preceding cycle.

The same diagram could also describe hostage taking or kidnapping, with various probabilities of the threat being executed, of the payoff averting the threat, and of a recycling and future recap of the contingency if the demand is met.

## Perceptions and predictions of $p$ and $M$

### Perceptions of $p$ : The basis for a wager

$aA^{M_1}$  and  $bA^{M_2}$  represent bets that  $a$  and  $b$  make in situation  $abC_5$ . They may be betting on, say, the outcomes of a ball game. The external agency  $e$  in this case would be two ball teams generating one of the two possible consequences. The attributes  $M_1$  and  $M_2$  of the bets can be the amounts of money  $a$  and  $b$  are betting. The symbol  $\cap$  indicates the “and” relationship of the bets, as in a contract. The notations  $^a p_1$  and  $^b p_2$  show that the two bettors  $a$  and  $b$  have different predictions or estimations of  $p_1$  and  $p_2$  (they probably wouldn’t be betting if they didn’t).

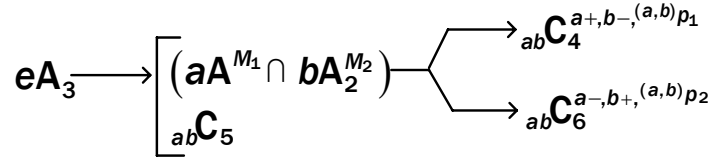

As was explained earlier, this notation is used when a party’s prediction of a probability is in some way idiosyncratic. The comma between the  $a$  and  $b$  pre-superscripts of  $p_1$  and  $p_2$  indicates that  $a$  and  $b$  have different predictions or estimations regarding  $p_1$  and  $p_2$ . If the pre-superscripts were  $ab$  without a comma, it would mean that  $a$  and  $b$  have a joint prediction.

### Perceptions of $p$ and of $M$ : Personal tipping

Different parties may also have perceptions of  $M$ s that differ from or are unrelated to the actual values. In the diagram below, if customer  $b$  has received a service ( ${}_a A$ ) from  $a$ , the magnitude  $M$  (actual amount of money) of the tip he gives

$(bA^M)$  may be  $M_1$ ,  $M_2$ , or  $M_3$ . The three tips are  $C_3$ ,  $C_7$ , and  $C_{11}$ . The three-way reciprocal vertical arrow shows that these three possible consequences are mutually exclusive.

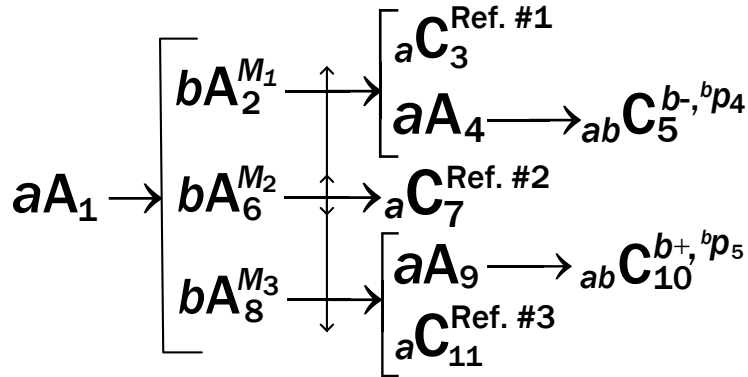

Ref.#1:  $(a^x)^{bp_1} M_1$     Ref.#2:  $(a^x)^{bp_2} M_2$     Ref.#3:  $(a^x)^{bp_3} M_3$

A tip's objective magnitude would not necessarily correspond to  $a$ 's perception of it. The magnitudes of these tips, as subjectively/idiosyncratically perceived by  $a$ , are attributes shown in the upper right quadrants of the three  $C$  s (Refs. #1, #2, and #3). This technique is used because if these attributes were scaled to the size of the main diagram and inserted, some parts of them would be too small to read).

Note that  $M_1$ ,  $M_2$ , and  $M_3$  in the expression  $bA^M$  have no pre-subscripts, as they refer to the actual dollar amounts. The fact that the two sets of three  $M$  s have the same (lower right) subscripts means that they refer to the same amounts of money.

The legend might state that  $a$  perceives  $M_1$  as too small,  $M_2$  as acceptable, and  $M_3$  as generous. The  $a^x$  s in the  $M$  s' lower left quadrants indicate that these perceptions are idiosyncratic and would result in different possible reactions,  $aA_4$  and  $aA_9$ .

To show that  $b$  would predict (perhaps because he has experience with) these possible idiosyncratic perceptions of  $M$  on the part of  $a$ ,  $b$  s are shown in the upper left quadrants of the three probabilities  $p_1$ ,  $p_2$ , and  $p_3$  that  $b$  would predict for those three perceptions, and those three probabilities are in turn shown in the upper right quadrants of the  $a^x$  s, because they are attributes of the  $a^x$  s.

$b$  would perceive the consequences  $C_5$  or  $C_{10}$  of  $aA_4 \rightarrow$  or  $aA_9 \rightarrow$ . Again,  $b$  predicts/estimates the probabilities  $p_4$  and  $p_5$  of  $C_5$  and  $C_{10}$  respectively.  $C_5$  might be an insult and  $C_{10}$  might be an expression of gratitude.

### ***Misperception of the M of a C: Perpetration of a fraud***

The  $M_4$  in the attribute quadrant of  $C_3$  refers to the magnitude or some scalable quantitative dimension of the  $C_3$ , in this case  $C_3$ 's value.

In the example below, if  $a$  offers ( $aA_1$ ) to sell  $b$  a counterfeit or fake painting,

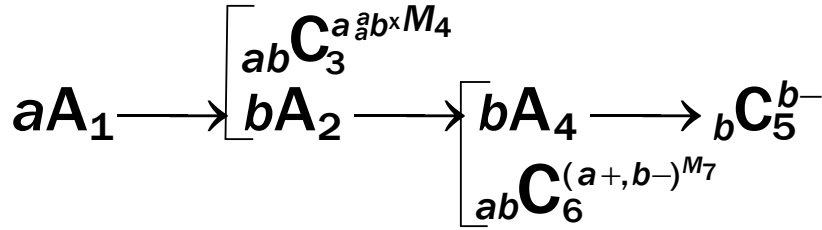

$C_3$ , the seller  $a$  would perceive the value of the painting to be  $M_4$  (as indicated by the  $a$  in the lower left quadrant of  $C_3$ ) while  $b$  would misperceive its value, indicated by the  $b^x$  in the lower left quadrant of  $M_4$ . Note that both  $a$  and  $b$  perceive the painting, but only  $b$  misperceives its value.

The  $a$  s in the two left quadrants of the  $b^x$  indicate that  $a$  would perceive and predict  $b$ 's misperception of the value. The description of  $aA_1$  in the legend might explain that  $a$  would, in addition, have caused  $b$ 's misperception by some previous actions, like telling  $b$  that the painting is very valuable.

Suppose, further, that  $b$  accepts  $a$ 's offer  $aA_1$  and buys the painting ( $bA_2$ ), paying  $a$  the asking price  $M_7$ . Here the  $M$  is the magnitude attribute of  $C_6$ 's valence. The valence for  $a$  would be the money that  $a$  is receiving and for  $b$  it would be the money with which  $b$  is parting.

If  $b$  subsequently gets the painting appraised ( $bA_4$ ) and learns its true value  $bC_5^{b-}$ , the valence of that information would be negative for  $b$ .

A further wrinkle could be the introduction of a third party  $c$  that witnesses the fraud and stands to benefit from it. The diagram could show  $c$ 's choice between warning  $b$  or letting the fraud occur, thereby becoming an accomplice.

## Complex Recycling Contingencies

### *Symmetrical reciprocal recycling contingencies: Feuding*

The diagram on the right represents a feud in which parties  $a$  and  $b$  take turns hurting each other. The crossing diagonal recycling arrows show the symmetry of this type of contingency. The reciprocal vertical arrow indicates the probabilities of the feud ending at any point.

Bargaining, where two parties take turns making each other offers and counteroffers, has a similar symmetrical recycling structure. The  $p_1$  and  $p_2$  are the probabilities that one of the offers would be accepted, ending the cycle.

A third example of the same contingency structure is the situation where two parties cooperate and take turns assisting each other.

### *Mutual deterrence and first strike*

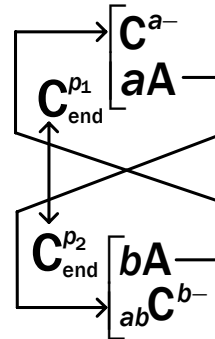

Another type of symmetrical recycling contingency that is often important in world affairs as well as in various other kinds of standoffs is mutual deterrence. Two factions  $a$  and  $b$  both have the option of launching a first strike. If  $a$  attacks first,  $b$  will retaliate unless  $a$ 's attack terminates  $b$ 's ability to do so. The protagonists will usually differ in their perceptions and predictions/estimations regarding the various probabilities that (a) the other party will execute a first strike, (b) the magnitude of the damage inflicted, (c) that there will be retaliation for each attack, that (d) the first strike will avert retaliation, and that (d) any given retaliation will end the cycle of exchanges. The protagonists may also differ in their assessments of the relative potential magnitudes of the negative consequences of every attack for each side. It is usually important also to consider each party's prediction/estimation of the other party's predictions/estimations of the various probabilities and magnitudes.

Contingency analysis and modeling of these types of situations (which include litigation, military issues, political campaigning, and other types of fighting) requires the use of computers, as it is cumbersome to perform by means of two-dimensional diagrams. It illustrates the potential value of behavioral contingency analysis in identifying and confronting all of the variables, including each side's perceptions, predictions, possible misperceptions and mispredictions, and uncertainties. In such applications, it can serve as a tool of operations research or computer simulation, and as an aid in fully understanding the game theoretic and behavioral dynamics that are operative in complex interactive situations.

## Progressive Changes and Registers

### *Pumping water into a bucket*

To indicate that a contingency can recycle a number of times  $n$ , the  $n$  can be written above the recycling arrow, as on the right.

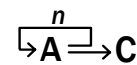

It is sometimes desired to show a register of the incrementally changed situation after each recycling. Such a register is conceptualized as a changing consequence  $C$  of each successive  $A$ . The diagram on the right describes a bucket being filled with water using a hand pump. Every pumping motion  $A$  increases the water level in the bucket by one increment  $\Delta L$ , shown as a subscript of the  $C_{\text{register}}$ .

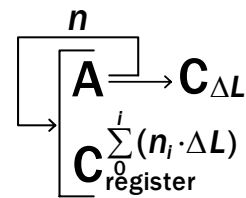

The  $C_{\text{register}}$  shows the amount of water in the bucket after  $n_i$  such  $A$ s. The symbol  $\Sigma$  shows the cumulative total number of times ( $n_i$ ) the  $A$  has recycled, times the change in the water level  $\Delta L$  with each cycle. The water level, an attribute of  $C$ , is shown in the  $C$ 's attribute quadrant.

Note that when the number of recyclings  $n_i$  is still zero, the register would show no water in the bucket yet. If ten recyclings are need to fill the bucket, the term  $C_{\text{full}}^{10 \cdot \Delta L}$  could be shown underneath the  $C_{\text{register}}$  term, if desired, since this is already true (though not yet achieved) starting even before the first  $A$ . Or, the

legend could state that the bucket would be full when  $n_i = 10$ .

***Short-term and long-term contingencies: Global warming***

The pumping contingency described above is similar to the many familiar cases where numerous repetitions of certain acts have a cumulative effect. The acts are often maintained by short-term positive consequences, on either individual, societal, or national levels, with cumulative long-term negative consequences.

The diagram below shows some of the behavioral dynamics of global warming—the cumulative consequence of many individual acts  $A$  like coal burning, burning of vegetation, and gasoline usage, that are maintained by their short-term positive consequences, with resulting long-term temperature change due to  $n_i$  repetitions of  $A$ .

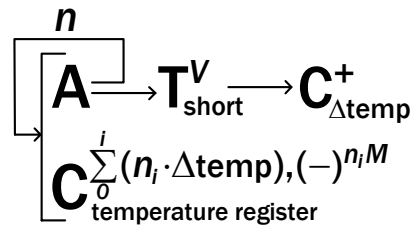

In this diagram, there is no identified end point of the process, unlike in the case of filling a bucket with water. The register  $C_{\text{temperature register}}$  is shown as having its magnitude (again shown by the formula in the exponent position) being cumulatively and progressively incremented, and the magnitude  $M$  of its negative valence increasing as a function of the number  $i$  of repetitions. If the analyst wished to highlight his prediction that the cumulative effect of  $n_i$  times  $\Delta temp$  will probably result in global warming over a long period of time, the additional expression  $T_{\text{long-term}} \rightarrow \bar{C}_{\text{global warming}}$  can be shown in the bracket.

***Long-term effects of smoking and similar contingencies***

Other familiar examples of this same contingency structure are the long-term effects of smoking or of consuming excessive sugar on health, and the environmental effects of overfishing, dumping wastes into waterways, destroying habitats of species, and the entire gamut of addictive behaviors.

The diagrams for all such contingencies have the same basic structural features—behavior that recycles, and generates positive short-term and negative long-term consequences. Only the descriptions of the  $A$ s and  $C$ s and of the variable that is being incremented (e.g.,  $\Delta h$  for health or  $\Delta temp$  for temperature, as in the above diagram for global warming) are different. In all these cases, the  $C_{\text{register}}$  would show the cumulative effect at every interim point.

***Registering points in a game: Keeping score and communicating it***

In many types of games, like basketball, soccer, and football, the winner is the player or team that scored the most points, often by the end of a certain time period. In the diagram for this type of game (right), every  $aA$  and  $bA$  represents the scoring of a point, and the register  $C_{\text{score register}}$  shows the score at every point

during the game, usually for all to see. The score corresponds to a magnitude dimension of the  $C_{\text{score register}}$ . The  $ab$  designators of the perceiving parties are assumed to be operative throughout, and are therefore not shown.

The summation formula (the magnitude dimension) shows the difference in the scores of the two teams at every point during the game. The sign of the difference would reflect the score of one competitor or the other.

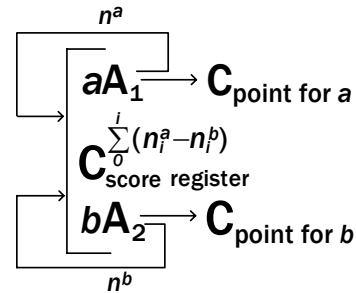

**Competition: Feedback regarding progress in races**

The following example illustrates a way to show that the game, race, or contest ends when one of the parties has crossed a finish line, has gained a certain number of points, or more points than the other party, at the end of time  $T$ , or has met some other possible definition of the goal  $G$  whose achievement determines the winner. The winner is declared, and the contest ended, by an external agency  $e$ . The other two contingencies in effect at the same time are those that concern the behavior of the two contestants, and the information they get during the contest about their progress in relation to that of the other contestants.

The  $aAs$  and  $bAs$  represent the contestants' acts that consequte progress toward the goal. These acts can consist of a runner's strides, a rower's oar strokes, or a skater's routines. The  $\Delta_a pr$  symbol represents an increment of  $a$ 's progress toward the goal, and,  $\Delta_b pr$  represents  $b$ 's. Each contestant's total progress after any particular number of  $As$  is represented by the summation of all his progress increments up to that point, shown in the two progress registers.

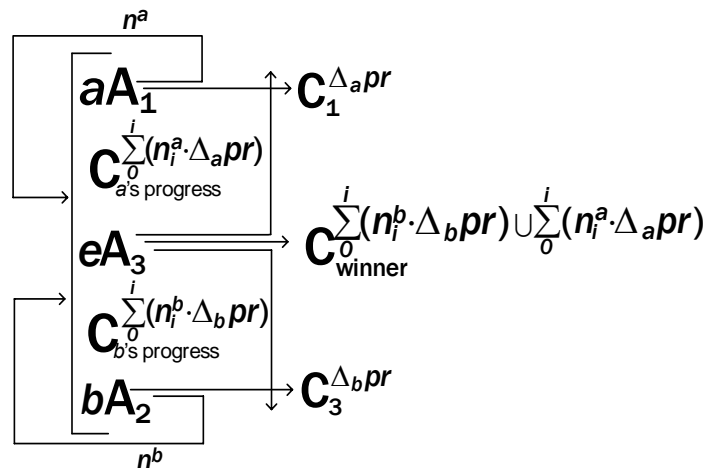

The winner is determined by the crossing of a finish line, or by some other criterion of victory such as a score that defines the winner. Note: (the  $\cup$  sign means "or"). The pre-subscripts of the progress registers (omitted in the above diagram) would show whether each party has access to their own and/or each other's

progress indicators.

In some types of races or contests, each party knows only its own state of progress toward the goal, and not that of the other party. *Examples:* The race between two independent research teams competing to be the first to publish an important discovery; two corporations competing to be first to bring a new product to market; athletes training for a competition. The above diagram would represent these types of competition as well.

### ***Financial registers: Accumulated interest and insurance premiums***

When a loan reaches its term, the interest payment cycle is terminated and the borrower *b* either repays the loan, renegotiates it, or defaults. From lender *a*'s point of view, this contingency would be represented by a three-pronged "or" fork with each branch having a different probability. In the case of a default, *a* then has a choice between several acts, each one having a different consequence. From *b*'s point of view, the consequences of *a*'s decision process would be represented by an "or" fork whose branches show the probabilities and consequences.

A register that displays the accumulated interest payments could show the loan's profitability to the lender.

Another familiar example whose analysis requires financial registers is an insurance contract, which usually involves the payment of insurance premiums on a time cycle analogous to that for interest payments. As in the case of a loan, a register for the accumulated premium payments reflects the perspective of the insurer. The diagram for the full contingency would show an external agency *e* that unpredictably generates possible mishaps against which the beneficiary is insured. Again, the possible acts of the insurer in case of such a mishap (*e.g.*, paying the award, disputing the entitlement, undertaking a study of circumstances), could be viewed from the beneficiary's point of view as an "or" fork with each fork having a different probability, or from the insurer's point of view as a choice or decision with reciprocal vertical arrows.

### ***National elections***

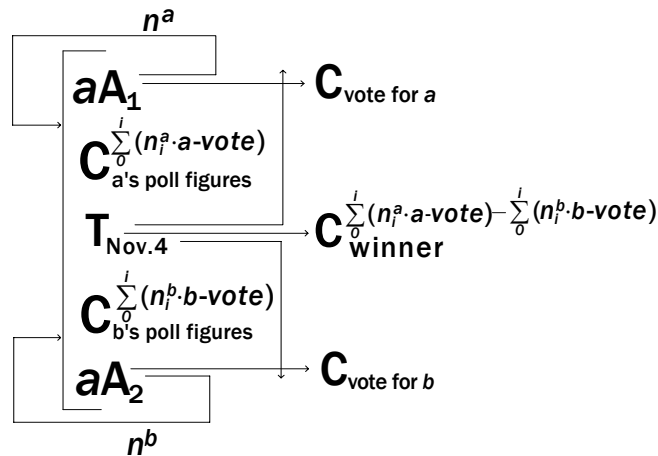

National elections involve a similar contingency. Here, the campaigning acts  $A$  of each of the two parties,  $a$  and  $b$ , consequate votes for that party.

The summation term in the two registers shows the presumed number of votes each party has accumulated up to any point in time, based, possibly, on polls.

$T$  is the time left to Election Day. The winner at the termination of that time period is determined by the difference between the votes accumulated up to that point by the two parties. While the diagram does not show pre-subscripts for the registers, it can be assumed that each party has access to the result of every poll, and that the  $ab$  pre-subscripts would therefore be justified.

### ***Linguistic analysis***

$A$ ,  $C$ ,  $T$ , and the involved parties can be conceptualized as the language's nouns; *perceive* and *predict* are verbs whose notation consists only of the quadrant placement of their agents; the two kinds of arrows are the other required verbs, to be read as *consequate* and *prevent*; and the attributes, along with the tilde for *not*,  $x$  for *mis-* and  $?$  for uncertainty symbols are the adjectives and adverbs that can modify entities. The symbols that indicate, *or*, and *and* relations, as well as the vertical bracket, which indicates simultaneity of onset, can be conceptualized as conjunctions. The rules for combining these elements, some of which are shown in the schematic diagram presented earlier, are part of the grammar. The hierarchical and recursive features of the structure are analogous to those found in many natural and formal languages.

The many possible combinations and permutations of the parties' perceptions, predictions, and the attributes of each entity, with the added dimension of the hierarchically nested modifiers of modifiers, constitute the palette that enables the language's four-noun-four-verb syntax to codify subtle nuances of meaning.

### ***Future evolution of the language***

The present contingency language, like any language, should be expected to evolve in response to new challenges. Such evolution is less likely to occur in the

language's four nouns (acts, party designators, time intervals, and consequences) or in its verbs (consequence, prevent, perceive, and predict), or in the hierarchical and recursive structure of the syntax, than in its modifiers (valence, probability, and magnitude), in the imported logic symbols, or in some of the rules of grammar for their manipulation and notation. It is possible that additional or other attributes will, in the future, be found useful for specialized applications, as in law, business, or economics.

However, even in its present form, the language can be seen to be sufficient for codifying the subtleties and nuances of the complex and varied contingencies illustrated by the selected examples, which were chosen for their diversity and for the range of challenges they present.

## **Practical applications of contingency analysis**

### *Using behavioral contingency analysis to address practical problems*

The behavioral contingency language can be regarded as a tool for addressing practical problem situations by analyzing and codifying the behavioral contingencies that are involved. In practice, however, the effort involved in codifying behavioral contingencies in any particular situation is worth the required time and effort only in some cases and not in others, depending on what is at stake. If the behavioral outcomes are important—potentially very valuable or very threatening—the time and effort may be justified. The result of the analysis may reveal that the contingencies are different from what they were thought to be, that there are some at play that weren't noticed, or that they are a special case of ones that are well understood.

### *Using prompts to get started*

The first step in analyzing any behavioral contingency is to answer certain questions about it. These questions can be stated as a set of prompts that the analyst can use as a kind of check list or algorithm. Such prompts would help the analyst to register every relevant thing he knows about the situation to be analyzed.

These could be some of the basic prompts:

- What parties are involved in the situation?
- What are the possible relevant acts of each party?
- What is your estimation of the probability of each of these acts?
- What is the possible consequence of each act if it occurred?
- What is your estimation of the probability of each of these consequences?
- Which, if any, acts would avert any of the consequences?
- Which, if any, acts would change any probabilities?
- Do any of the consequences have significant time lags?
- Which if any acts terminate or change any of these time periods?
- What is the valence or magnitude of each consequence for each party?

- Which party(ies) perceives, does not perceive, or misperceives each of the acts, consequences, perceptions, predictions, time periods, valences, or probabilities?
- Which party(ies) predicts, does not predict, or mis-predicts each of these?
- What possible new acts would each of the listed consequences occasion? (Repeat all of the above prompts for the possible new acts and their consequences).

Just going through the process of responding to these types of prompts would generally improve an analyst's understanding of the operative contingencies, the parties to be taken into account, and the factors to be considered. The process would increase the number of relevant variable with which the analyst makes contact, including variables that could otherwise easily escape notice. The analyst would also be prompted to identify all areas of ignorance or uncertainty about the situation being analyzed, and to confront these.

### ***Generating the contingency structures***

The larger and more intricate types of diagrams, like some of the ones presented in this paper, are difficult to lay out in two dimensions and draw. For complex situations, assembling the answers to the questionnaire items into integrated contingency structures would require computer software. Such software would convert the registered information into multi-dimensional behavioral contingency structures that would exist only in the computer memory, with the capability to print out diagrams of particular portions of the structures. The analyst would use such printouts as planning and analysis aids, and also for the purpose of checking and debugging the codifications of the contingencies.

The development of software with these capabilities is one of the next steps in the implementation of a practical technology for the analysis of complex behavioral contingencies. It would seem that a competent programmer who has understood the present paper but who does not necessarily have a strong background in psychology or behavior analysis should be able to write the software for generating such virtual diagrams.

### ***Predicting behavioral outcomes***

The analyst's goal would usually be to gain a better understanding of the behavioral contingencies that are at play in the situation being analyzed, so as to improve his ability to predict what behavior may occur, and to modify the prevailing contingencies so as to modify that behavior.

The contingency structures that an analyst produces would flow directly from the information, beliefs, and assumptions he registered and entered in response to the prompts. His resulting predictions of the behavioral dynamics that can be expected would reflect whatever he knows about the behavioral effects of various types of contingencies and variables. The main elements of such a knowledge base would consist of the behavioral effects of

- various types of behavioral histories
- presenting, withholding, or signaling rewards and punishments of various relative magnitudes and probabilities,
- presenting or withholding cues and information regarding prevailing contingencies, and
- time factors.

The contingency diagrams obviously do not embody such knowledge and therefore cannot generate predictions of what behavior should be expected to occur for any given set of contingencies. Only someone armed with the relevant body of knowledge provided by the behavioral sciences can make such predictions and modify the behavioral outcomes of contingencies accordingly. As the data base of knowledge provided by the behavioral sciences continues to expand, the usefulness of behavioral contingency analysis can be expected to increase correspondingly.

### ***The behavioral contingency analysis process***

The application of behavioral contingency analysis in the manner described above will inevitably include an iterative process of revisiting and adjusting the contingency information that was originally entered in response to the prompts according to the behavioral dynamics being predicted by the contingency structure that was produced. If the analyst sees a discrepancy between the predicted dynamics and his expectations, he would have the option of making such adjustments. By this iterative process, he would increase his understanding of the relationship between the features of the contingency structure being analyzed and the behavioral outcomes that can be expected.

Such an understanding can provide the basis for modifying or even designing the behavioral contingencies in situations that lend themselves to such intervention. The modification and design of outcomes by this general method could become one of the practical uses of the contingency analysis system, and a valuable tool in operations research, computer simulation, and in the modeling and management of behavioral contingencies in any area of human affairs.

## **References**

Chisholm, D.C. & Cook, D.A. (1995). A model of cause-effect relations in the study of behavior. *The Behavior Analyst*, 18, 99-111

Findley, J.D. (1962). An experimental outline for building and exploring multi-operant behavior repertoires. *Journal of the Experimental Analysis of Behavior*, 5, 113-166.

Goldwater, B.C. & Acker, L.E. (1995). A descriptive Notation System for contingency diagramming in Behavior Analysis. *The Behavior Analyst*, 18, 113-121.

Keller, F.S. & Schoenfeld, W.N. (1950). *Principles of Psychology*. Appleton Century Crofts.

- Malott, R.W., Whaley, D.L., & Malott, M.E., (1993). *Elementary principles of behavior*. Englewood Cliffs, NJ: Prentice-Hall.
- Mattaini, M.A. (1995). Contingency diagrams as teaching tools. *The Behavior Analyst*, 18, 93-98.
- Mechner, F. (1959). A notation system for the description of behavioral procedures. *Journal of the Experimental Analysis of Behavior*, 2, 133-150.
- Mechner, F. & Latranyi, M. (1963). Behavioral effects of caffeine, methamphetamine, and methylphenidate in the rat. *Journal of the Experimental Analysis of Behavior*, 6, 331-342.
- Michael, J. (1963). *Laboratory studies in operant behavior*. New York, McGraw-Hill.
- Michael, J. & Shafer, E. (1995). State notation for teaching about behavioral procedures. *The Behavior Analyst*, 18, 123-140.
- Millenson, J. (1979). *Principles of behavior analysis*. New York: McMillan and Co.
- Pierce, W.D. & Epling, W. F. (1995). *Behavior analysis and learning*. Englewood Cliffs, NJ: Prentice-Hall.
- Sidman, M. (2004). Meeting the world halfway. Association for Behavior Analysis Conference.
- Skinner, B. F. (1958). Diagramming schedules of reinforcement. *Journal of the Experimental Analysis of Behavior*, 1, 67-68.
- Snapper, A.G., Kadden, R.M., and Inglis, G.B. 1982. Computer technology: State notation of behavioral procedures. *Behavior Research Methods and Instrumentation* 14:329-342.
- Stephens, K.R. & van Haaren, F.P. The origins and development of state notation and SKED. *Behavior Research Methods and Instrumentation*, 1977, 9, 72-74.
- Tanaka, H. K., & Nomura, M. (1993). SN-FORTH/MSX: A state notation system for controlling behavioral experiments with a low-priced computer. *Nippon Seirigaku Zasshi*, 55(2), 47-53.
- Weingarten, K., & Mechner, F. (1966). A notation system for the analysis of social interaction. In T. Verhave (Ed.), *Readings in the Experimental Analysis of Behavior* (pp. 447-459). New York: Appleton Century Crofts. (See also <http://www.mechnerfoundation.org/>)

## **Author's Note**

Contact information:

Francis Mechner  
200 Central Park South, 18E  
New York, NY 10019  
[fmechner@panix.com](mailto:fmechner@panix.com)

The author wishes to express his deep appreciation for the valuable suggestions made by Jack Marr, Murray Sidman, and Lanny Fields, and for the valuable editorial assistance of Laurilyn D. Jones and Karyn Slutsky.

**Running Head:** Behavioral contingency analysis